

Static DC transformer based on Negative Capacitance and high voltage engineering

Deepalakshmi Chandrasekaran

SS Maintenance, TNEB, India.

¹dldeepasekar@gmail.com

Abstract— For DC voltage amplification, the operational amplifier is mostly used in the non-inverting configuration. In this case, the DC voltage amplification is done using a negative capacitance converter. Since the feedback capacitor acts as an open circuit for DC signal, it provides isolation between input and output. The amplified voltage level is limited by the breakdown voltage of the transistors used to build the op-amp and further the insulation breakdown limit of the Miller capacitor. By making use of new technologies such as silicon carbide technology, the breakdown voltage of transistors can be made higher even 1.2 KV and combined with high voltage engineering for capacitive insulation such as polymer capacitors, this can become a huge breakthrough in electric power engineering. Additionally, it can be used as an effective DC source for electric vehicles. The nominal voltage used in hybrid vehicles ranges from 100V to 200V. For electric-only vehicles, the required voltage is as high as 800V. The simulations are done using MIT Circuit sandbox, an open source circuit simulation tool.

Keywords— DC amplifier, Op-amp, negative capacitance, silicon carbide and high voltage insulation.

I. INTRODUCTION

The negative capacitance effect has become the spotlight of research interest due to its interesting applications. The negative capacitance effect can be exploited to do DC voltage amplification[1]. It exhibits inductive like nature and hence it can replace the bulky inductor in circuits. Therefore, it acts as a low pass filter. In contrast to normal Op-amp DC voltage amplifier circuits, the output current is not fed back to input, hence it is more stable. In Op-amp negative capacitance converter, Miller capacitance is used. It can be used for capacitance load compensation in ultra low power CMOS circuits.

II. EXISTING DC AMPLIFIER

DC voltage amplification using non-inverting configuration of Op-amp[2]

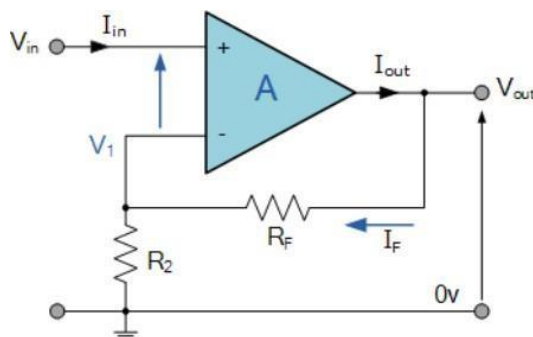

Fig.1.Non-inverting amplifier

The transfer function is given by

$$V_{out} = [1 + (R_f/R_2)] V_{in}$$

V_{out} =output voltage(V)

V_{in} =input voltage(V)

R_f =feedback resistance(Ω)

R_2 =input resistance(Ω)

A non-inverting op amp is an operational amplifier circuit with an output voltage that is in phase with the input signal. In this configuration, the input voltage signal is applied directly to the non-inverting input terminal. Feedback control of the non-inverting operational amplifier is achieved by applying a small part of the output voltage signal back to the inverting input terminal through feedback resistor R_f - R_2 voltage divider network, again producing negative feedback. This closed-loop

configuration produces a non-inverting amplifier circuit with very good stability, a very high input impedance, R_{in} approaching infinity, as no current flows into the positive input terminal, (ideal condition) and a low output impedance, R_{out} .

For an ideal op-amp, no current flows into the input terminal of the amplifier because the junction of the input and feedback signal are at the same potential. This junction is a virtual earth summing point. Because of this virtual earth node the resistors, R_f and R_2 form a simple potential divider network across the non-inverting amplifier with the voltage gain of the circuit being determined by the ratios of R_2 and R_f .

A. Circuit Simulation

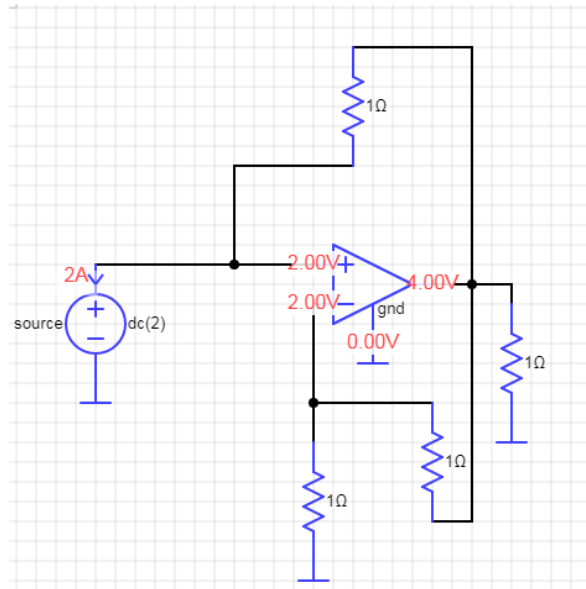

Fig.2. Amplifying 2V to 4V

III. PROPOSED METHOD

In the proposed method, DC voltage amplification is done using negative capacitance converter. The negative capacitance circuits are very interesting analog building blocks with many possible applications like the compensation of undesired parasitic capacitance, bandwidth enhancement of amplifiers, equalization filters design without passive inductors[3]. The feedback capacitor is a Miller capacitor and it acts as a high voltage decoupler between input and output.

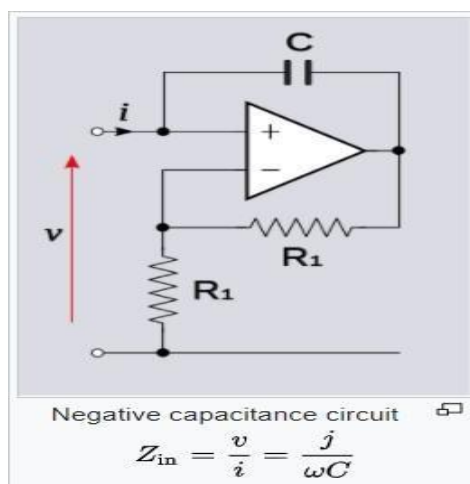

FIG 3

Voltage transfer function at the output point is given by

$$\text{Output voltage} = [1 + (R_f/R_1)] * V_{in},$$

same as in the case of Non-inverting amplifier configuration.

B. Circuit Simulation

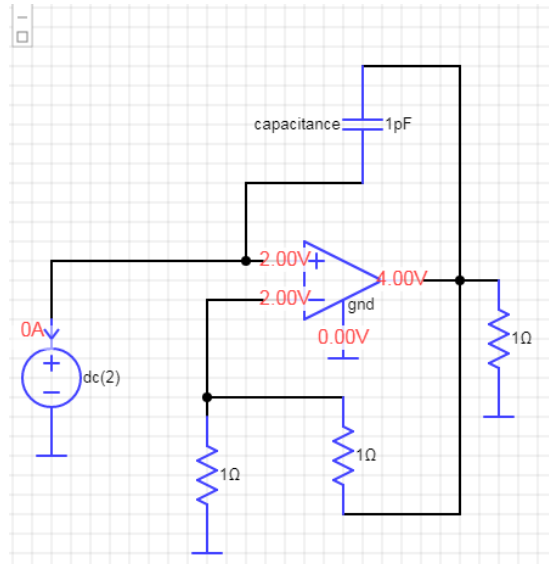

FIG 4.NCC AMPLIFYING 2V TO 4V W/O FEEDBACK CURRENT(0AMP)

IV FROM 1V TO 1.1 KV

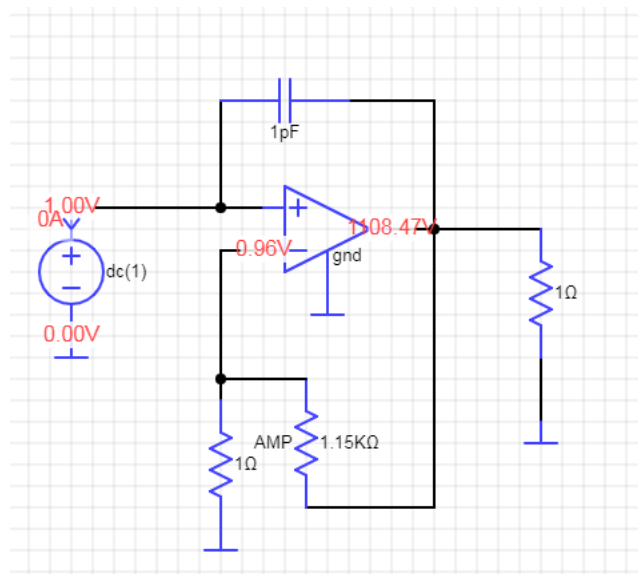

Fig 5.NCC amplifying 1V to 1.1 KV (1108.4 V)

Here comes Silicon Carbide technology to rescue that the breakdown voltage of SiC MOSFETs can be made higher to withstand even 1.2 KV[4] and SiC Op-amp is also available[5]. Similarly, the dielectric insulation of feedback capacitor should

withstand high voltage without the possibility for capacitor failure. Some of the polymer capacitors[6] available in the market have the rating of 100 V to 150 KVdc. In India, mostly the generation voltages are in the range of 1.1 KV and can be easily generated with the input of 1V by using these recent advancements in high voltage engineering.

For electric-only vehicles, efficient power converters are essential particularly DC-DC converter. The voltage range of hybrid vehicles ranges from 100 V to 200 V. For electric-only vehicles, the required voltage range upto 800V. This proposed method can be used as an effective DC source for electric vehicles.

V SUSTAINABLE SILICON CARBIDE TECHNOLOGY

Recent research has shown that SiC can be produced from electronic wastes and hence it is eco-friendly[7]. Initially, rare earth elements are used to produce SiC. Also, SiC increases the sustainability of renewable energy process. It is mostly used in power electronics.

VI CONCLUSION AND FUTURE WORK

This method can be effectively used for DC voltage amplification. It can be used as a DC transformer by providing different values of resistance in the feedback resistor at the inverting terminal. If milliohm resistor is used, the voltage can be stepped down to the required voltage level. The feedback capacitor acts as decoupler between input and output. The problem addressed in the nature article cited[8], the fundamental understanding of negative capacitance can be further improved by studying the electromagnetic aspects of the proposed negative capacitance converter in doing comparison study at the ferroelectric material level.

REFERENCES

- [1] Salahuddin, S. & Datta, *Use of Negative Capacitance to Provide Voltage Amplification for Low Power Nanoscale Devices*, S. Nano Lett. 8, 405–410 (2008)
- [2] Roy Choudhury, Shail B. Jain – *Linear Integrated Circuits*, New Age International Publishers, chapter-2, pg.no-56, (2004)
- [3] Bosko Mrkovic, Martina Asenbrenner, *The simple CMOS negative capacitance with improved frequency response*, 2012 Proceedings of the 35th International convention MIPRO, 21-25 May 2012.
- [4] 'Power Up Expo' Virtual Conference under Solid State Electrification, Dec-9, 2021 EE times and Power Electronics News
- [5] Silicon Carbide – Leading the way geaviation.com
- [6] Type KVx High-Voltage and Pulse, Mica-Paper/Polymer Capacitors, arrow.com
- [7] Sk S.Hossain & P.K.Roy, *Sustainable ceramics derived from solid wastes: a review*, Journal of Asian Ceramic Societies, Vol 8, 2020 issue 4, pg 984-1009
- [8] Rethinking negative capacitance research, Nat Electron 3, 503(2020)